

TAPRX-888 SDR

and

Measuring Time of Arrival / Flight

- A new true open-source SDR, based on the RX-888
- Hardware and software developments, designed to add accurate time dimension measurements to the wsprdaemon network.

Introduction

Paul Elliott:

- Retired electronics engineer
- Vice President TAPR BOD
- Ham Extra – WB6CXC – first licensed around 1974
- Became involved with HamSCI via the wsprdaemon group
- I don't get on the air much, but I like designing stuff
- Have a *very* small company to make / sell these designs:



First, About the TAPRX-888

Based on Oscar Steila's BBRF103, the RX-888 SDR has been a game-changer:

- 100 kHz – 60 MHz continuous coverage
- Wide dynamic range – 16-bit ADC
- Full-bandwidth digitized spectrum sent to host computer for processing by ka9q-radio
- Adopted as the preferred receiver for wsprdaemon and the HamSCI Personal Space Weather Station

The RX-888



First, About the TAPRX-888

But:

- Can be hard to find, especially with the prevalence of clones and scam-sellers on aliexpress
- Internal anti-alias filter is marginal
- MF, LF sensitivity is poor
- Thermal issues, requiring mechanical heat-transfer improvements
- For precision frequency measurements it needs an external reference clock adaptor
- Hardware design (schematics and PCB) are **not** open-source

The RX-888



First, About the TAPRX-888

So we decided to design a new SDR

- Based on the BBRF103 → RX-888
- Eliminated VHF converter and other unused components.
- Improved and flexible filtering and low-frequency performance.
- Input for external reference clock
- Input for time-synchronization source
- Improved thermal design
- Larger PCB, allowing easier future development
- **True open-source from TAPR**

About to go out for prototype build!

TAPRX-888

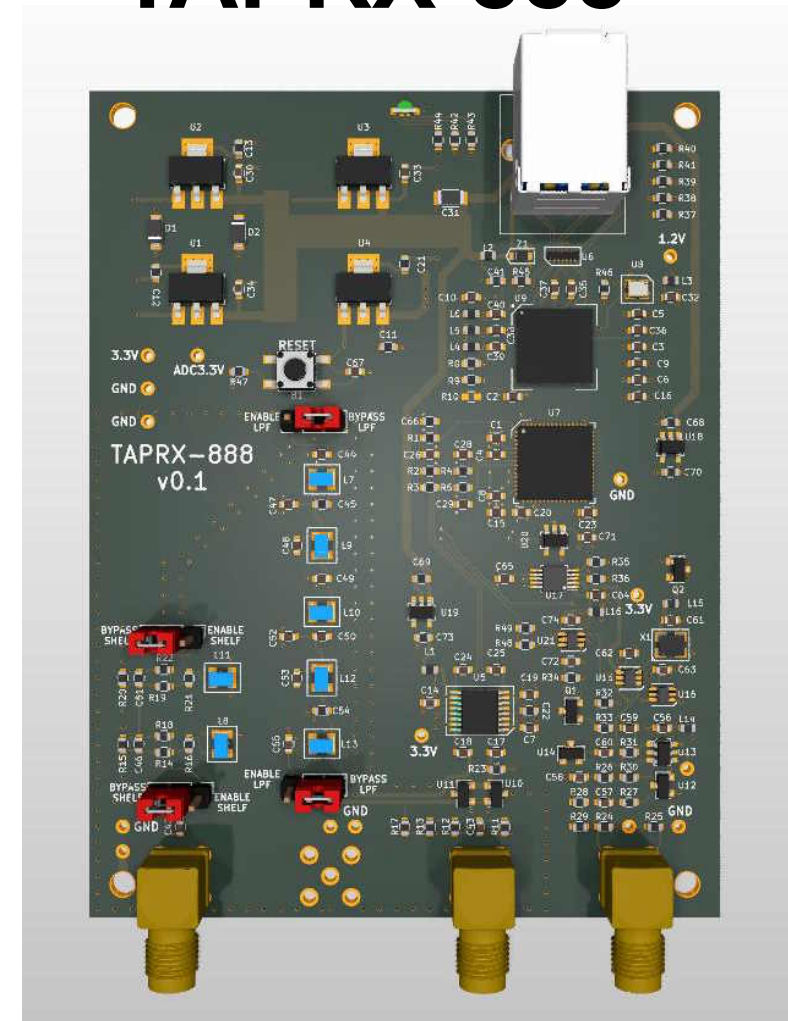

Radio Propagation Time Of Flight

Measurements:

wsprdaemon / TAPR / HamSCI – Work in Progress

We are working hard to add **Time of Arrival** and **Time Of Flight** measurements to the global wsprdaemon receiver network

These measurements will aid in the study of multi-path transmission and validation of propagation models.

This presentation will show both hardware and software developments, current and planned, designed to add accurate time dimension measurements to the wsprdaemon network.

Introduction

The HamSCI and wsprdaemon communities have made great progress in developing a distributed network of transmitters and receivers capable of using WSPR / FST4W and other modes to measure the Doppler shift and several other parameters of propagated signals across many different paths and frequencies. We are typically measuring Doppler shift with better than 10 millihz accuracy.

Introduction

But one parameter we've only occasionally explored is Time of Flight and related measurements. This is not new technology by any means, but this presentation will describe tests and equipment designed to be “ham-friendly” and easy to set up. We still have much work to do – transmitter design, transmit protocols, decoding software, database design, etc. – these are definitely ongoing projects.

This presentation will cover a bit of relevant history, some work in progress, and plans for the future.

Terminology

TOT: Time of Transmission

TOF: Time of Flight

TOA: Time of Arrival

TDOA: Time Difference of Arrival

PPS: Pulse Per Second

LOP: Line of Position

LORAN: Uses three known-location transmitters. The unknown-location receiver measures the TDOA to determine two hyperbolic Lines of Position. The intersection of these two LOPs is the receiver's position. Approximately. After GPS became affordable many fishing boats ripped out their war-surplus LORAN units, so about 45 years ago I bought one and used it to figure out the Lat/Lon of my garage. This was the genesis of my interest in Time of Flight

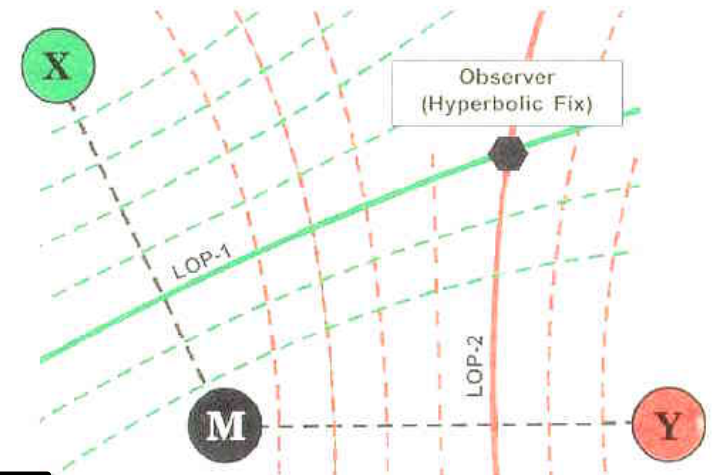

This is not a new thing for the HamSCI community

- Hams have been deploying Time of Arrival-measuring systems for LF/VLF signals – Jonathan Rizzo (KCEEY)*
- And have been using WWV time-tick TOA measurements to differentiate among various propagation modes – Steve Cerwin (WA5FRF)*
- Adding chirp modulation signal to WWV for TOF analysis – Kristina Collins (KD8OCT)*
- Transmit, receive, and recording of PPS BPSK signal during the 2023 / 2024 solar eclipses – Clint Turner (KA7OEI)*

Most of the HF TOF/TOA work to date has used WWV, WWVH as the transmit source. More transmit locations should be useful.

Most received-signal analysis has been in a single location (or just a few). More time-synched receive sites should be useful.

* See links at end of presentation for more details

Next Steps?

- **Goal: simple, inexpensive, easy to deploy transmit and receive TOF/TOA systems, integrated into the wsprdaemon network and database.**
- This is a “tool kit” approach, providing data for general propagation analysis.
- Receiver timesync resolution and accuracy 1 us (or better). TOA accuracy depends on signal characteristics.
- Timesync capability is easily added to existing GPSSDO-referenced RX-888 receivers.
- Timestamp transmitter is quite flexible – a good thing since protocols are TBD!
- Add TOA / TOF times to wsprdaemon database

A Timing Authority Taxonomy:

- L6 — HF PPS injection
- L5 — GPS+PPS via USB into radiod machine
- L4 — GPS+PPS (local timeserver) on LAN
- L3 — hf-timestd UTC recovery
- L2 — NTP WAN time sync
- L1 — wall clock
- L0 — wall clock and no GPSDO

L1-6 assume GPSDO referenced receiver sample clock

A proposed time-accuracy rating for receivers used in
Time of Arrival measurements
(Courtesy of Michael Huan, AC0G)

Time Sync Injector

The injector generates a clock signal that is BPSK (Binary Phase Shift Keying) with carrier phase alternating on GPS PPS intervals.

This signal is coupled into the RX-888 SDR “HF” input. There is essentially no filtering of the square wave modulation – resulting in a wide modulation bandwidth – but this isn't an issue in this application.

The signal frequency is 84.225 MHz, which is above the RX888 Nyquist frequency (the RX-888 sample clock is 129.6 MHz). This signal is aliased down to 45.375 MHz where it is demodulated and decoded by ka9q-radio, then used to establish the .wav file timestamps.

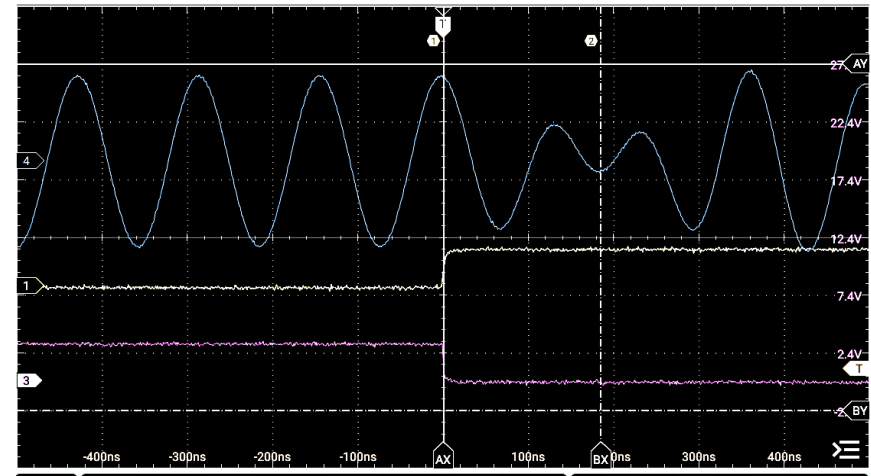
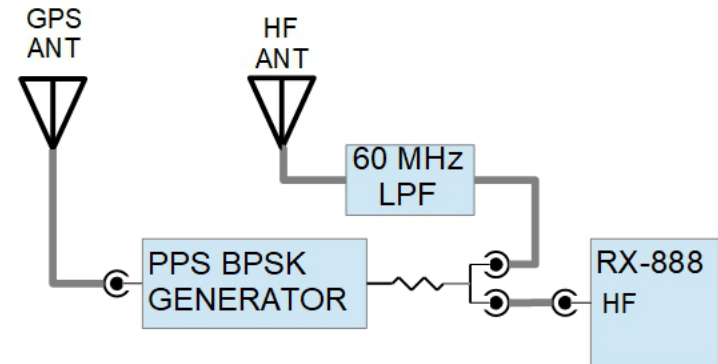

Why 84.225 MHz?

The signal frequency is 84.225 MHz, which is above the RX888 Nyquist frequency (the RX-888 sample clock is 129.6 MHz).

This high frequency was chosen to eliminate potential re-transmission of the BPSK signal.

The typical external low-pass filter (or filter + preamp) will attenuate this signal by 70 dB or more before it reaches the antenna. With the injector level at -33 dBm this means any re-transmitted signal will be less than 1 picowatt.

This 84 MHz signal will be further attenuated by the RX-888 internal LPF by about 25 dB.

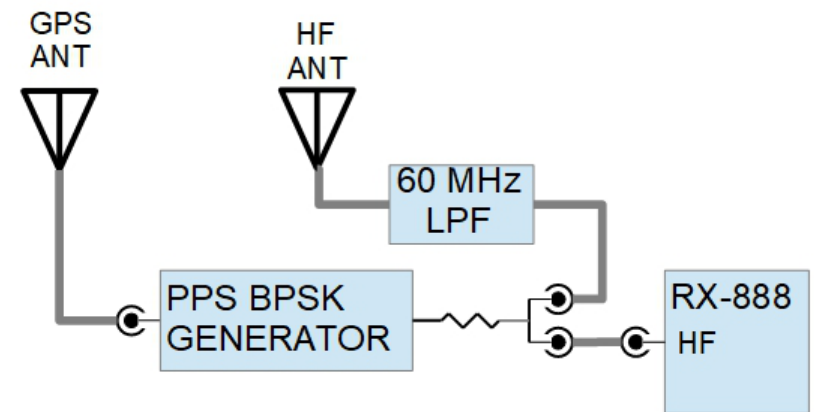

Some RX-888 installations use half-rate sampling, which puts the aliased BPSK signal at 19.425 MHz. The BPSK signal frequency was chosen to ensure that with either sample rate all harmonics out to the 7th do not alias any closer than 475 KHz to any “ham-interesting” band (including WWV, etc.)

Proof of Concept

- First try at a PPS BPSK timesync injector
- Input: PPS and 84.225 MHz clock (from dual-output Bodnar)
- Output: RX-888 SDR
- Using ka9q-radio code, timesync code by Scott Newell
- After testing, installed at WW0WWV (Ft. Collins CO)

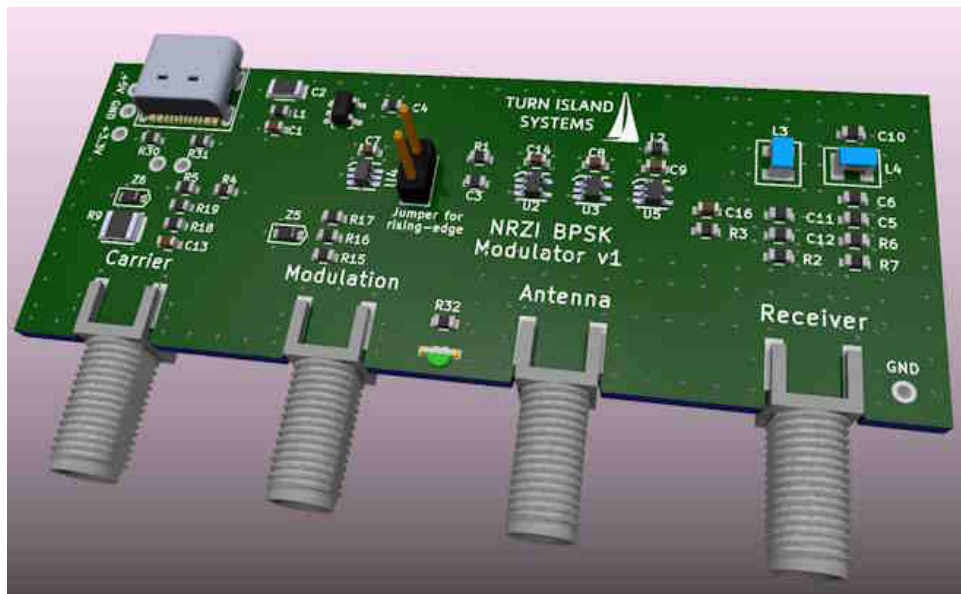
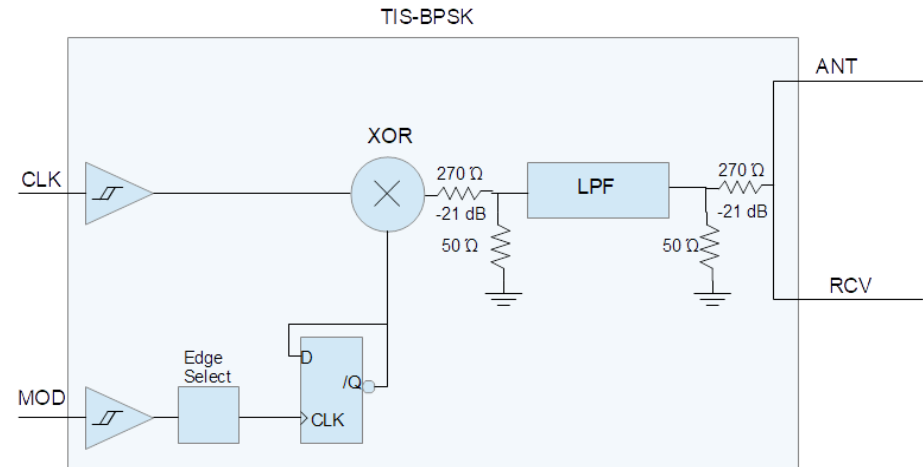

Puzzling Evidence

To verify the performance of the TimeSync modulator / receiver system we used the WWV time-tick transmissions on all frequencies as a local (near-field) timestamp reference signal. It worked great, with better than microsecond resolution – but after a while a problem was revealed:

Why is the measured delay **drifting 5us / week**? A software bug?

It **can't** be the RX-888 reference clock! – that's a GPSDO set to 27 MHz.

Or can it???

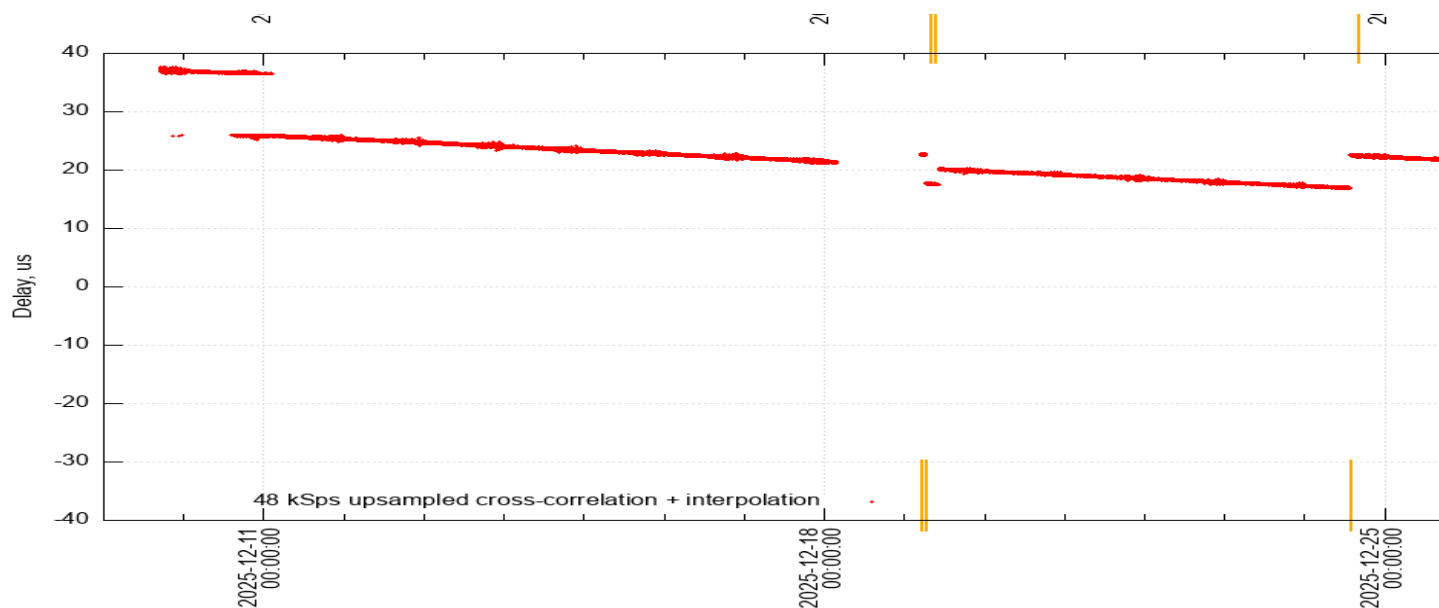

Fun fact: there are significant delays in getting the WWV time-ticks out to the antennas, and each transmit frequency has a different delay:

<https://www.nist.gov/system/files/documents/calibrations/sp250-67.pdf> (page 134)

Measuring the Bodnar Mini

26 Hours of Phase Drift, Bodnar Mini v1.14

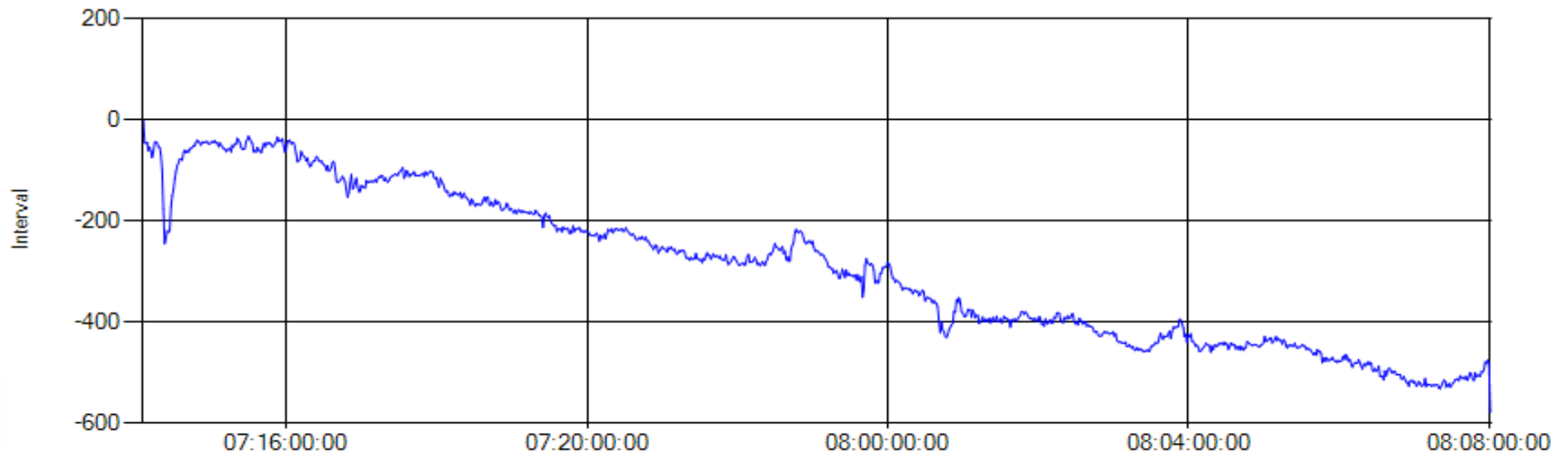

Notes: ns phase drift

- Using GPS PPS to measure phase drift of Bodnar Mini v1.14
- uController timer clocked by 27 MHz Bodnar, sampled by PPS ISR (two sources of jitter)
- Vertical: ns
- Horizontal: day:hour:minute:second
- About **8 ps/second drift** (more or less, noisy measurement) : about 216 uHz freq error.

Your GPSDO May Not Be Perfect

After much testing we determined that the Bodnar miniGPS *as shipped* has an output **frequency error of about 200 uHz** when delivering a 27 MHz clock. While this is not significant in typical SDR operation and measurement of Doppler shift, it will result in a slow addition of phase error when measuring TOA – about 17 ns per hour.

Apparently this error is a deliberate trade-off for faster GPS clock acquisition and settling. But there is a firmware update that eliminates this error: v1.20, available from Bodnar.

The newer LBE-1420 does not have this frequency error.



miniGPS



LBE-1420

Verifying the Bodnar Mini v1.2 Accuracy

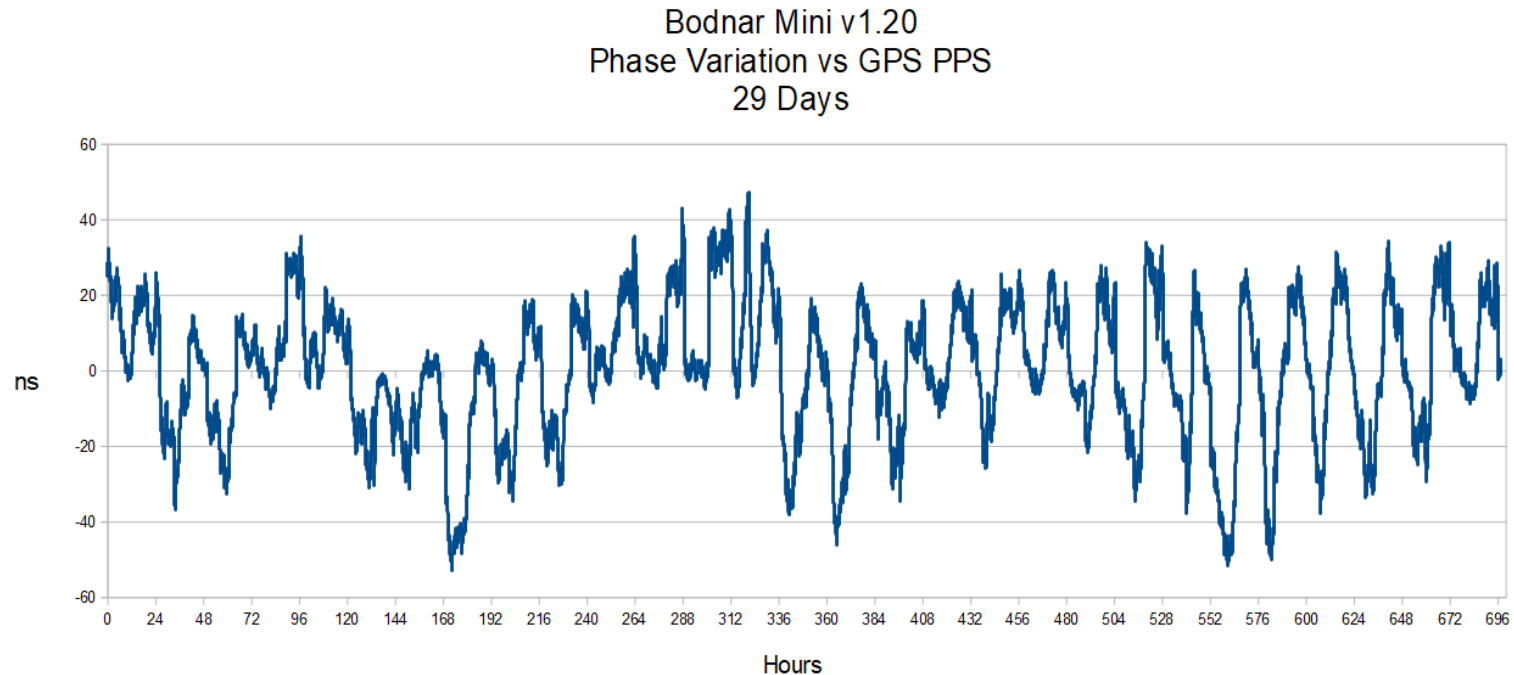

This is a 29-day test showing zero accumulated phase error. The diurnal (daily) and longer periodic phase offsets are interesting, and no doubt understood – just not by me!

Regardless, the measured phase error of under +/- 60 ns is well below our system target of 1us.

The TIS-TS1 TimeSync

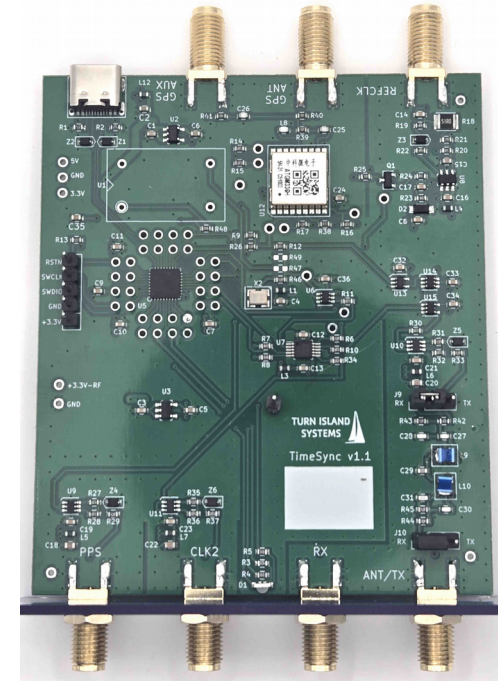
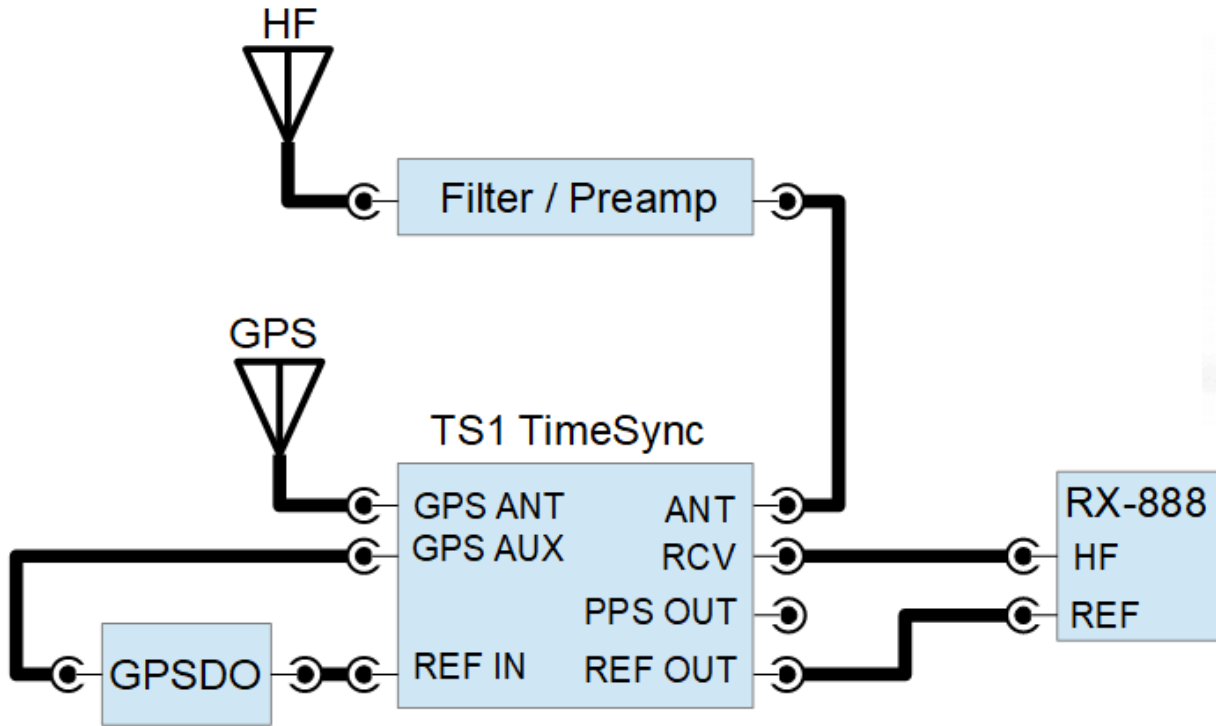

So I designed the TS1 TimeSync. This has the same PPS-modulated carrier injection, but eliminates the need for a second GPSDO. It also provides for timestamped transmit mode with a 10 mW output (refinements to come).

The TimeSync

- Easy upgrade to existing RX-888 PSWS installations
- Fairly inexpensive (approx \$170)
- Can use any typical GPSDO reference clock frequency
- Can generate any output clock frequency (receiver sync input, or transmitter output)
- With ka9q-radio updates lets the RX-888 be used for many types of TOA measurement
- The TimeSync can serve as a timestamped transmitter with better than 500 ns accuracy. (formats in development and TBD)
- USB/serial port available for monitoring and configuration, software updates

The TimeSync at KPH

On Feb 16 2026 Rob and I installed a prototype Timesync at the KPH receiver site. The hardest part was squeezing the box into place on a crowded shelf.

But with three SMA jumpers and a USB connection the TimeSync was quickly in service.



Results: WWV to KPH Time of Flight

We have just begun testing and refining the system, but here is an example of a TOF measurement using the TimeSync and Scott Newell's ka9q-radio additions:

Here we see 24 hours of WWV “top of minute” signal reception at KPH – a 1570 km path, and a measured TOF of about 5.5 ms.

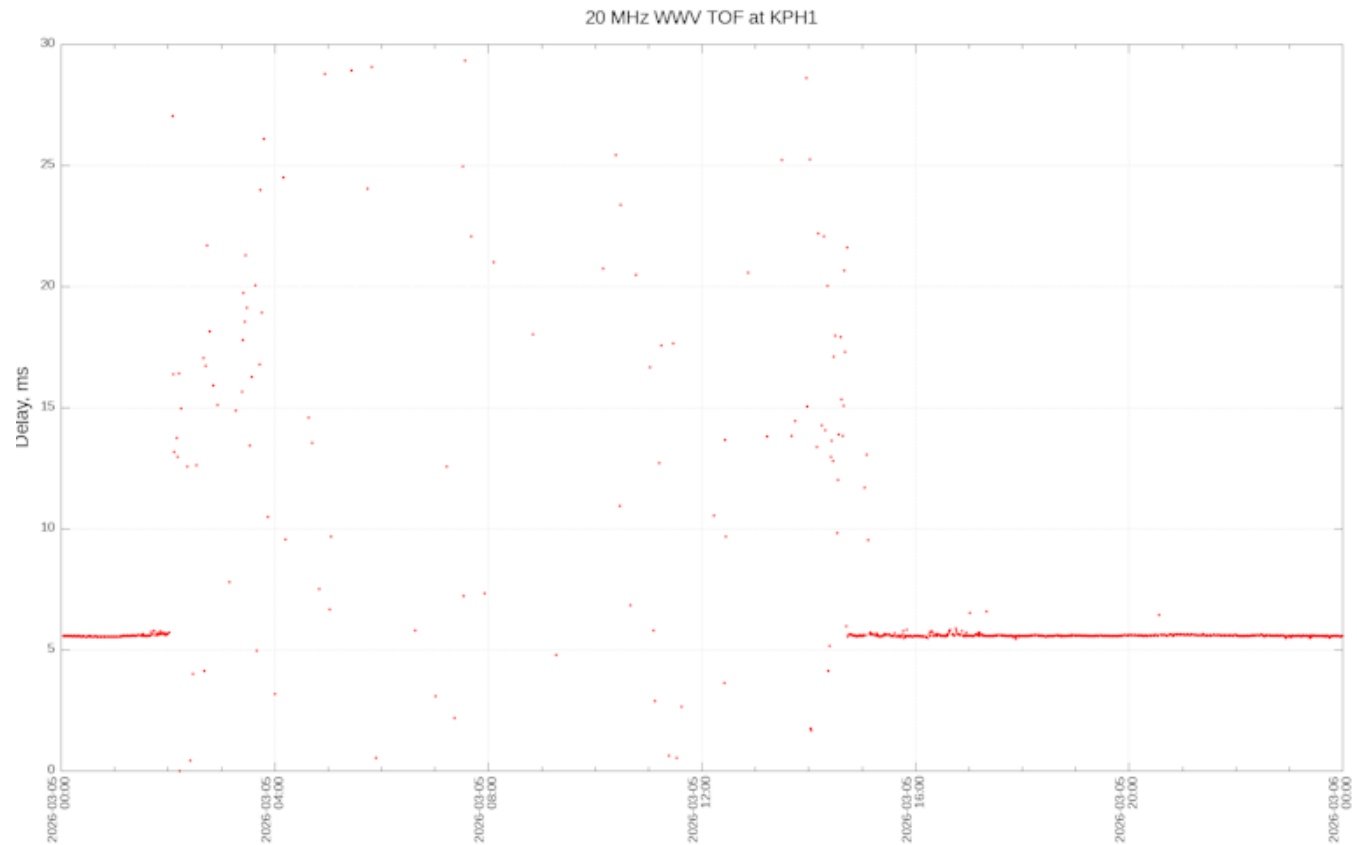

Using the TimeSync as a Transmitter

Potential Modes:

- Simple PPS BPSK
 - Very narrow bandwidth
 - Takes a long time to obtain high-resolution TOA measurements
 - Station ID needs additional information
- Faster PRBS BPSK symbol rates
 - Faster and more precise TOA measurement
 - Potentially multiple transmitters on the same frequency using low cross-correlation Gold Codes (using the GPA CA code)
- Adding modulation envelope filtering
 - Narrower occupied bandwidth, less interference to nearby signals

Simple BPSK Amplitude Control

Envelope shaping is done by varying the supply voltage to the output driver, which is a simple 74LVC digital buffer.

This device is being operated somewhat “off-label”, but as it is specified to provide full-output swing with a supply voltage range from 1.65V to 5.5V it performs well as an amplitude modulator.

The buffer accepts a 0-3.3V logic level input regardless of supply voltage.

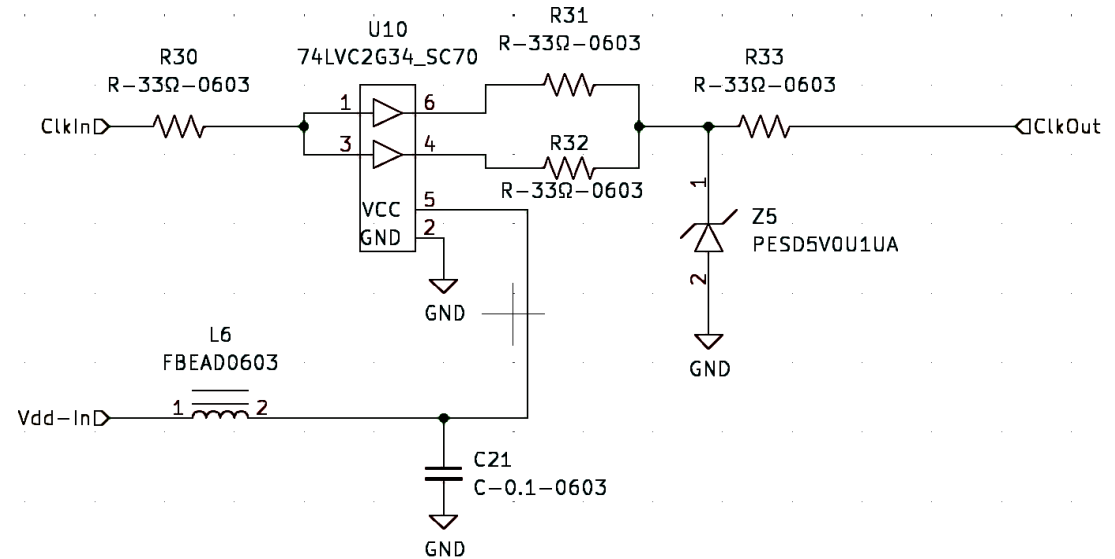

For more output power, multiple driver packages can be used in a transformer push-pull configuration, as is being done in the Turn Island Systems WSPRSONDE

Simple BPSK Amplitude Control

Amplitude Control of Power Supply

The driver supply voltage is provided by a simple rail-to-rail input / output op-amp. The amplifier used has a relatively high current capability output, and is able to drive the buffer Vdd practically up to the +5V supply rail.

The amplifier is driven by the microcontroller internal DAC (with a 0-3.3V output range) and provides low-pass filtering and voltage gain so the +3.3V input drives the output to about 4.8V.

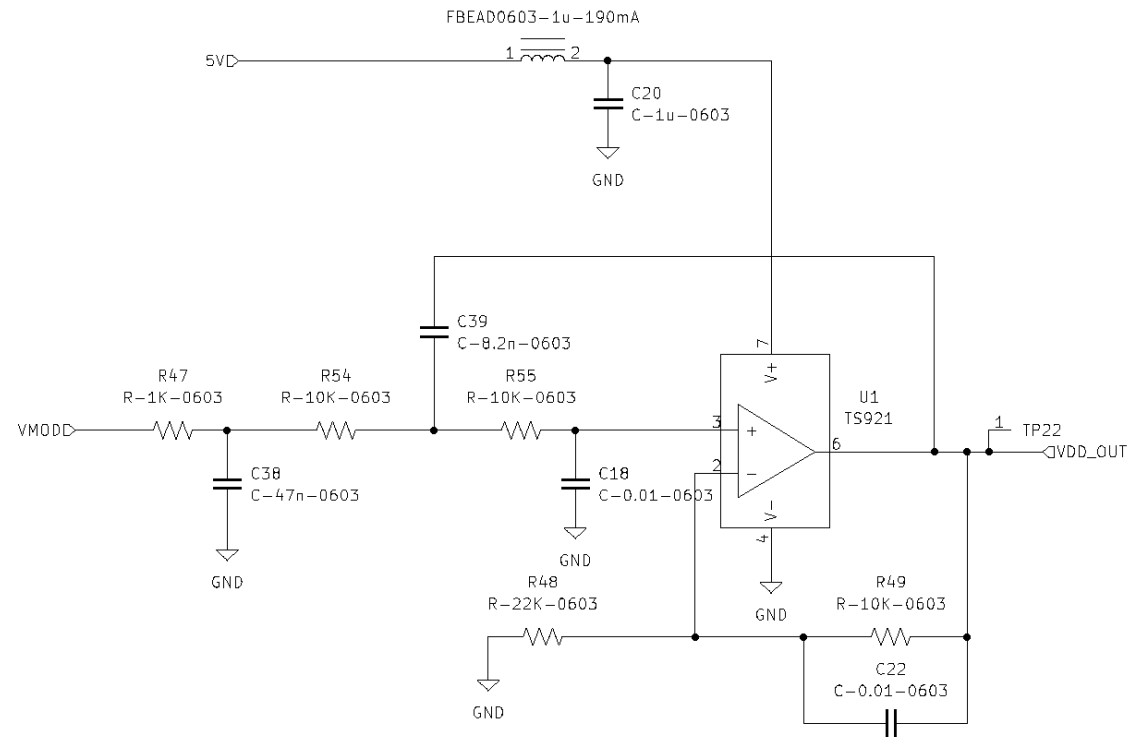

Simple BPSK Amplitude Control

Control Voltage Generation

The DAC control values are generated using an interrupt-driven FIR (Finite Impulse Response) filter, clocked at a 2.043 kHz rate. This interrupt also generates the BPSK data.

There are multiple FIR patterns available, ranging from 1 to 16 samples in width.

The image shows the stairstepped DAC output, and the filtered driver supply voltage:

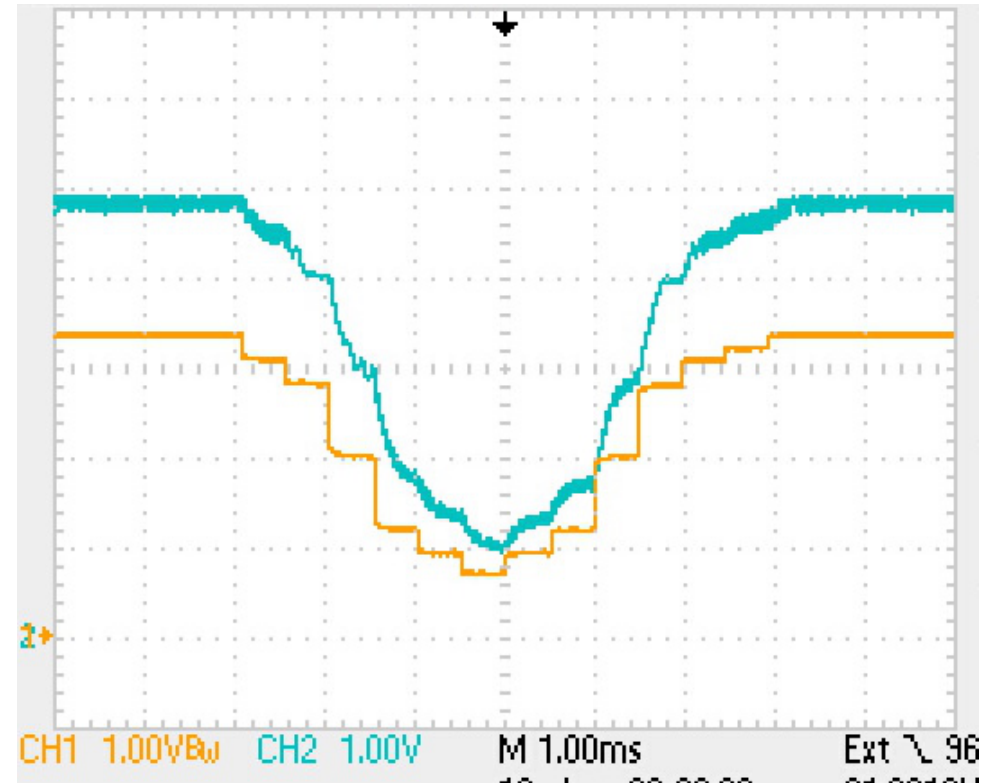

Simple BPSK Amplitude Control



The modulated BPSK carrier envelope during phase transition

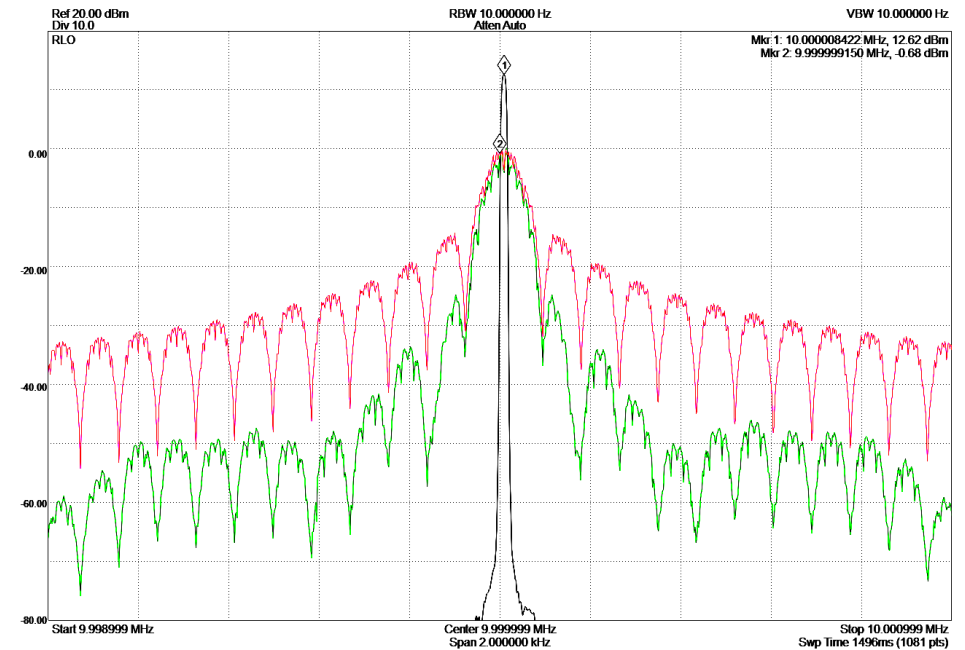

The spectrum, with and without envelope shaping

One More Modulation Picture

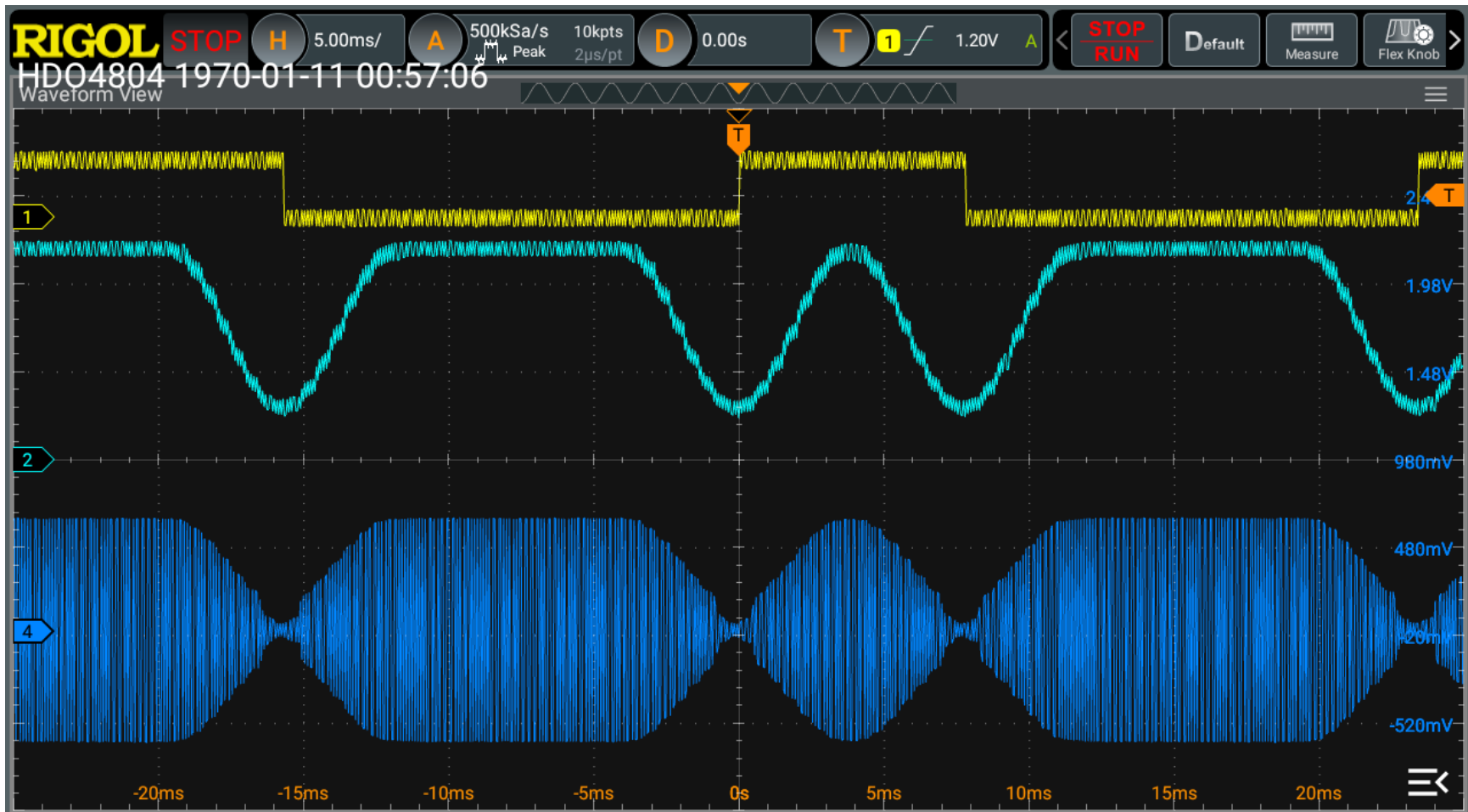

This is maximum filtering – I like this one because it shows the raised-cosine envelope so well.

Some Demodulation Pictures

Over the air testing:

Transmitting at a 511.5 Hz chip bit rate, the PRBS pattern repeats every two seconds. Process gain: 30 dB

Upper chart: one minute worth of correlation peaks.

Lower chart: expanded look at a correlation peak.

The PRBS pattern provides excellent time resolution.

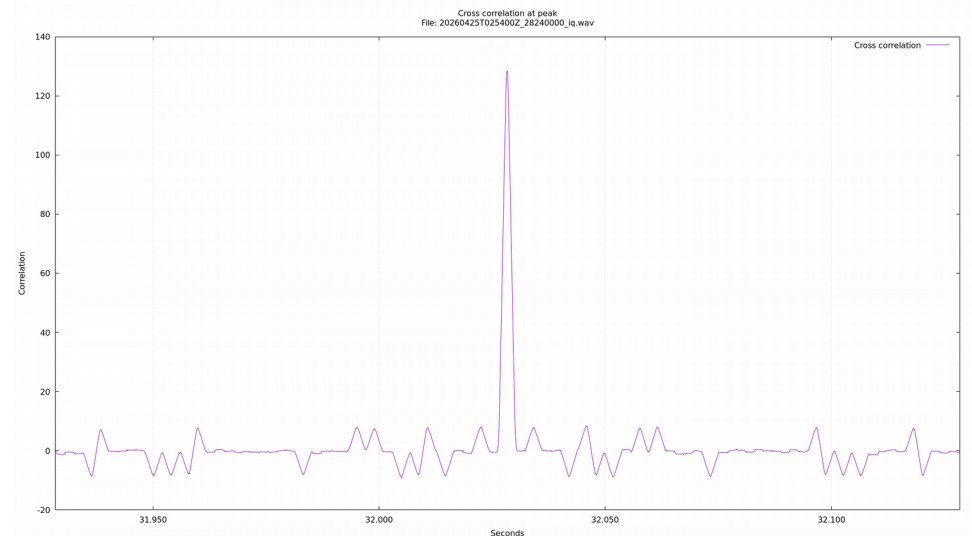
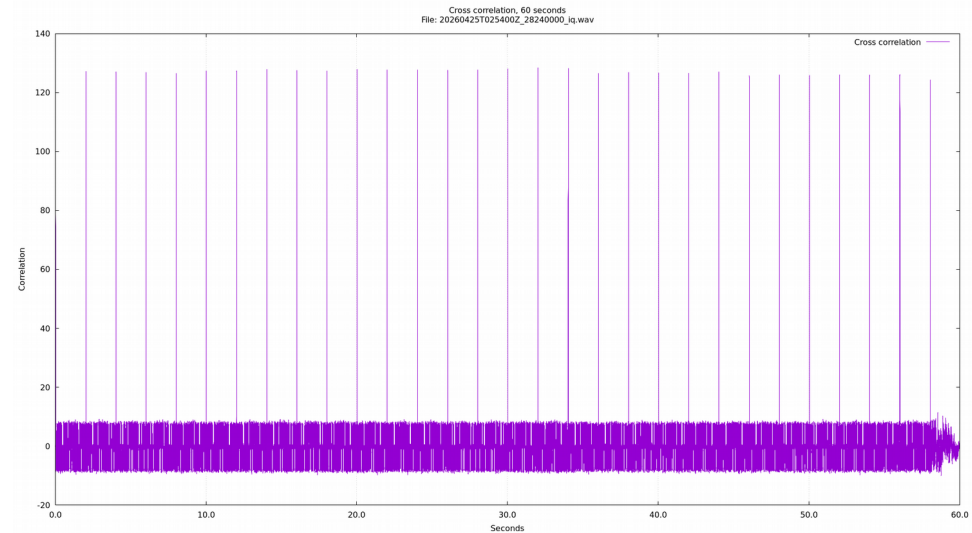

Charts courtesy Scott Newell

Summary

- Easy to deploy TimeSync design, now available for installation
- BPSK pulse shaping for timestamp transmitter application
- Starting work on wsprdaemon database to include TOA / TOF measurements
- Starting timestamp transmitter protocol development
- ka9q-radio timesync software development continues
- TOF data from the WWV to KD7EFG path (using Clint Turner's BPSK timesync injector) has been used by Gwyn Griffiths to validate propagation analysis tools

Links

- **Jonathan Rizzo - The DASI2 HamSCI Whistler Catcher VLF Reception System**
<https://hamsci.org/publications/dasi2-hamsci-whistler-catcher-vlf-reception-system>
- **Clint Turner - Technical description - KA7OEI Eclipse TX and RX equipment -**
https://www.ka7oei.com/eclipse/eclipse_gear_1b.pdf
- **Clint Turner - Multi-band transmitter and monitoring system for Eclipse monitoring**
<https://ka7oei.blogspot.com/2023/10/multi-band-transmitter-and-monitoring.html>
- **Steve Cerwin - WWV Time Tick Arrival Time Study to Investigate Multiple Modes During Daily Dawn and Dusk Transitions** <https://www.youtube.com/watch?v=LlzJb4HGjiM>
- **Steve Cerwin - HamSCI HF multipath propagation mode analysis [...] time difference of arrival**
<https://www.frontiersin.org/journals/astronomy-and-space-sciences/articles/10.3389/fspas.2026.1723511/full>
- **Kristina Collins - WWV/H Scientific Modulation**
<https://www.hamsci.org/wwv>
- **Gwynn Griffiths - A Python data analysis and synthesis toolbox for PSWS Doppler data: A time-of flight case study**
<https://hamsci.org/hamsci-2026-program>
- **Michael Huan - Multi-Static HF Time Signal Analysis for Ionospheric Sounding and TEC Estimation**
https://hamsci.org/sites/default/files/article/Workshop_2026/HamSCI_2026_AC0G.pdf
- **TAPR**
<https://tapr.org/>
- **HamSCI**
<http://hamsci.org>
- **Turn Island Systems**
<https://turnislandsystems.com/>
- **wsprdaemon**
<https://www.wsprdaemon.org/>