

Packet Status Register

Number 22



Tucson Amateur Packet Radio Corporation

PRESIDENT'S CORNER

Lyle Johnson, WA7GXD

Hope you all liked the September issue of PSR/PRM! As you know, it was our premier combined issue. I think Gwyn and his crew in Florida did an excellent job!

Of course, if you have any suggestions for improvements, please write to Gwyn or TAPR.

PSX

The major topic I want to present to you this month is PSX, the TAPR Packet Software Exchange.

I erroneously reported in the July PSRQ that Tom Clark would be heading up the PSX effort. Tom in fact had declined due to time pressures from other commitments. The error in reporting this rests squarely with me.

However, the poll results show a mandate from the membership to establish a software exchange, so we will attempt to get it going!

The purpose of PSX is to provide tested, packet-oriented software at very low cost. To do this requires software (!) and a method to duplicate it.

Let's look at these problems, and perhaps see how you can help make this effort a success.

SOFTWARE

We are looking for programs like terminal emulators, binary file transfer utilities and bulletin boards.

We need these programs for the whole gamut of personal computers likely to be found in a typical ham's shack. The list includes Commodore 64 and 128; Amiga; Atari 520ST and 1040ST; IBM PC and PCjr; Radio Shack Models 1, 2, 3, 4 and Color Computers; and Apple 2, 2c, 2e and Macintosh.

We want programs that are known to work well with the various TNCs on the market, including of course the TNC 1 and TNC 2 models developed by TAPR.

And we are looking for software that is either (1) public domain or (2) shareware. This is because we want to distribute the diskettes at a very low price, in the \$5 to \$10 range. The idea is for PSX to pay its own way and provide a service, but not to provide any significant TAPR operating revenues.

We need folks with the above-mentioned computers to act as testers for the software. The documentation must be verified. The interface to the TNC must be tested.

Does the program crash? Does it conflict with various accessories that may be installed in the computer? Can it handle various displays? If it is designed to display in color, is it useable with monochrome CRTs attached to the color display port?

DUPLICATION

We also need volunteers to duplicate the disks. TAPR will provide the diskettes and pay the postage to get the blanks to you and the duplicated diskettes returned to the TAPR office.

DISTRIBUTION

The TAPR office can handle all the details of accepting orders, shipping programs, etc.

ETC.

As you can see, getting an operation like this rolling will require a lot of effort from many folks. It can only work if you really want it to, because it will depend on you!

"Why do we need this?" you ask. "Aren't there already plenty of programs out there for these machines?"

Perhaps there are. If so, please help us locate them. We get lots of requests at the office for software for various computers. Computer dealers seem not to be knowledgeable about modem programs, or only have very expensive ones to sell. Many packeteers joining our ranks today are computer novices; they are in packet for the communications potential, not the technical aspect.

And, while there may be plenty of programs out there that allow you to operate your computer as a dumb terminal, there aren't many that allow you to use your computer as a smart packet-oriented communications system. Or personal message boxes. Or gateways. Or automated OSCAR/packet systems. Or...

POSITION OPEN - PAYS THE SAME AS THE PRESIDENCY!

Finally, we need a volunteer with the time, energy and dedication to organize PSX and get it rolling. I will help; but, like Tom, I have too many other commitments that would prevent me from being an effective PSX administrator. *Continued on page 12.*

PSK MODEMS FOR FO-12

Tom Clark, W3IWI

This is a brief report on FO-12 PSK modem progress. The TAPRites (NOADI, WA7GXD & W3IWI) have been working on an adaptation of the JARL/JAMSAT PSK demodulator described in August 1986 QEX. (The QEX article only covers the 'dem' part of the required modem).

Our plan is for TAPR to make this design available as a reproducible package -- it has not yet been decided whether this will be a full kit or a semi-kit; if it is the latter, then all parts not supplied will be available from Radio Shack, JAMECO, or similar suppliers.

>>> Details will be announced just as soon as <<<
>>> they are decided. <<<
>>> Please don't bug us about availability yet! <<<

There are several differences (all additions) from the QEX design. The modem is designed to work with a TNC1 (including Heath HD4040 and AEA PK-1) or TNC2 (including MFJ, Pac-Comm, AEA PK-80 & GLB TNC2 clones) and connects thru the 20-pin 'modem disconnect' header plus the normal radio I/O jack. The modem has an IN/OUT switch so that you can change between FO-12 and normal terrestrial operation without swapping any cables. If you try to use this design with another type of TNC, you will have to insure that you have access to the RX data input to the TNC at TTL level bypassing the normal FSK demod. You will also have to provide the 'raw' TTL level TX data and TX clock (either 16x or 32x baud rate) and you should also provide a 'carrier detect' input to the TNC (active low) so that the TNC will know when the modem is locked up.

The modem has been designed with digital AFC to interface to any of the more modern all-mode radios. This involves having the radio make 10 Hz (e.g. with TS811) or 20 Hz (e.g. with FT726) steps using the inputs that allow to step up/down from buttons on the microphone.

Our design includes two modulators: Manchester FSK as required for the FO-12 uplink and 1200 baud PSK. The PSK modulator has been included for two reasons -- it lets you run loop-back tests with the PSK demod, and more importantly, it allows amateur experimentation with PSK packets. PSK should be 10-20 dB superior to the 'Bell 202' AFSK-FM in common use on VHF. The composite PSK signal generated by the modulator is your normal digital data exclusive-or'd with an audio carrier in the 1400 to 1800 Hz range (exact frequency chosen to match your SSB radio's filters).

The design also includes LED 'bar graph' indicators for both received signal level and tuning. The interface to the uplink radio are the normal TX audio and PTT lines. Your transmitter must operate in FM for the Manchester FSK FO-12 uplink or SSB for PSK use. On the receive side, your SSB receiver supplies RX audio to the demodulator, and preferably should support digital frequency stepping for the AFC circuit described earlier.

Here at W3IWI I now have a full functional prototype running. I want to thank Tak Okamoto (JA2PKI) for providing me with JA-land circuit board which made my life a lot easier! I have been running local loopback tests and am convinced that the basic design is sound. 'Eye-patterns' on the PSK demod show that data filters are nearly optimal, and lock-up time is quite acceptable.

The next step in my testing will involve cramming 1200 baud PSK thru ordinary commercial radios to characterize their performance. I have some concern about the filters in commonly used radios since I found a couple of years ago that a stock FT726 was unsuitable for 1200 baud FSK work. Initial testing will be done on the Kenwood TS711/811 pair and an FT726. If someone wants to loan an IC-271/IC471 pair we will gladly test them too. I am very anxious to find some other packeteer within 150 miles who has an FO-12 modem running so that I can make real 'on-the-air' tests.

The other 'next step' is to finalize the circuit board layout and test that implementation. We will keep you posted as this work proceeds.

- PRM -

TAPR PRICE LIST

The following price list is current for October, 1986.

Memberships:

Associate (no PSR/PRM)

\$5.00/year

Full (PSR/PRM included)

\$15.00/year in the US

\$18.00/year in Canada

\$25.00/year elsewhere

LSC-10 Coffee Mug

\$5.00 (only at Hamfests!)

(see you at Ham/West in Las Vegas!)

Introduction to Packet Video

\$10.00 postpaid in the US

(available in VHS format only)

HF Tuning Indicator Kit

\$25.00 postpaid in the US

(see October 1985 PSR for circuit)

9600 baud Modem Semi-Kit *

\$25.00 postpaid in the US

(see K9NG article in 4th ARRL Proceedings)

FADPAD Xerox 820 Adapter *

\$25.00 postpaid in the US

(PC board and data only)

FUJI/OSCAR 12 PSK Modem

To Be Announced

TNC 1 OEM package

\$500 one-time charge

TNC 2 OEM package

\$5,000 one-time charge plus royalties

neither complete nor supported by TAPR.

* These products are for experimenters and are neither complete nor supported by TAPR.

- PRM -

STEALING

It has finally happened!

Amateur packet radio is being plagued by groups pursuing immoral, if not downright illegal, activities. These thieves are, knowingly or not, stealing from TAPR on a daily basis. These are not Robin Hoods; they are doing it to line their own pockets.

And they are not "just stealing from TAPR," they are stealing from you!

As well as the customers who support their activities.

How are they doing this?

They are manufacturing and distributing unauthorized clones of TNC 2 hardware, software and documentation.

Where are the hotbeds of this activity?

Germany and Japan.

There is a consortium of four amateurs in Germany who have reworked the TNC 2 pc layout and are selling, through 4 separate addresses, the PC board(s), parts kits, TNC 2 manual and TNC 2 software ROMs.

Now, there is nothing sacred about the TNC 2 design, and a new PC board is not violating any copyrights. But the TNC 2 manual is copyrighted. And the software is copyrighted as well.

These crooks have been contacted by letter and choose to disregard our requests that they play fair.

Perhaps they think the license cost is too high?

Five dollars (10 Deutsche Marks at current exchange rates) is a pretty paltry sum to pay for a royalty. They are simply capitalizing on the TNC 2 design work done by TAPR volunteers, and by not supporting TAPR they are robbing the tills of needed capital to continue with networking development.

Their customers, trying to save a very few dollars, are also expecting to reap the benefits of networking when it arrives, but shirking any responsibility for helping to support the development of that network.

And legitimate Amateur dealers in Germany and surrounding areas are losing business to these folks.

Some people call this piracy.

Hah!

THEY ARE STEALING.

They are stealing from the unrequited toil of volunteers who did the TNC 2 design. They are stealing from TAPR, who established the Amateur TNC marketplace in the first place. They are stealing from YOU.

And now, we find a report in Gateway that a thought-to-be respectable Japanese manufacturer of Amateur equipment, Maki Denki Co., is also selling a TNC 2 clone without licensing the design from TAPR. The president of this company was quoted by Gateway as stating that he wasn't doing anything wrong!

What would he think if someone walked into his warehouse and took all his goods, then sold them in the stall next to him at an Amateur show? Would he think they had done anything wrong?

I certainly hope our members and other members of the Amateur fraternity will put pressure on these thieves by not purchasing their products of any type, as well as write to the editors of their respective Amateur journals to see to it that no advertising is accepted from these unprincipled people.

If any of you run across any TNC-2-like products from any source that doesn't explicitly claim to be licensed by TAPR, please let us know at the office so we can (1) contact them and inform them of the OEM agreement and (2) blow the whistle on them while we (3) map our strategy to deal with them.

Packet radio has been a gentlemen's arena up until now. Let's keep it that way.

- PRM -

HAM/WEST

TAPR will have a booth at the upcoming HAM/WEST Convention to be held in Las Vegas on Friday and Saturday, November 7th and 8th, 1986.

There will be two packet forums held each day; an introductory session conducted by Dave Pederson, N7BHC, of Utah Packet Radio Association (UPRA) and an advanced session conducted by Lyle Johnson, WA7GXD.

So, whether you are looking for information on packet basics, or want to discuss topics such as satellite or high-speed operation, mark your calendar and plan to attend HAM/WEST '86. Both forums will be conducted each day - consult the program schedule.

See you there!

- PRM -

Renewal Reminder

Please check your mailing label on the front cover of this issue of PRM. If you are a TAPR member, there will be a number in the center of the top line. It indicates the month and year of your membership expiration.

If your expiration date is 01-87 or earlier, please take a moment to renew.

Don't put it off, or you may miss an issue or two of PRM and PSR!

MODS FOR AMATEUR PACKET

ALASKA HF MOD KIT

Lyle Johnson, WA7GXD

At the Dayton Hamvention I spoke with one of the folks from Amateur Packet Alaska, who have been selling an HF mod kit for the TNC 1 and TNC 2 units. The kit cost \$30 back in April; I expect it has not changed.

Upon my return to Tucson, I built the unit (it consists of a PC board, an IC, a few resistors and capacitors, a switch and very clear directions). It went together easily and worked as expected.

However, being the type of person who can't leave well enough alone, and having just been exposed to the modem mods proposed by Dan, KV7B, and Eric, N7CL, I opened the case of my TNC 2 and went to work once more.

I changed the 510k resistor on the header that plugs into socket U19 to 750k, then changed the 226k resistor on the APA board to 180k and the 47k resistor to 36k.

This was fine as far as it went, but there were still two problem areas: baud rate selection lock-detect loop timing.

One drawback of the APA modification kit is that, in order to switch between 300 baud and 1200 baud operation, you need to toggle the supplied switch mounted on the front panel, then reach behind the TNC 2 and fiddle with the baud rate switch.

Not convenient.

The solution was quite simple. The supplied SPST switch for mounting on the front panel of the TNC was replaced with a DPDT, center-off toggle switch. One pole of the switch was wired up to the APA adapter as before. The other pole was wired up to DIPswitch SW2. The center pin (common) connects to SW2 pins 9, 10 and 11. The 300 baud position of the new switch connects to SW2 pin 6, while the 1200 baud position connects to SW2 pin 7.

When operating, SW2 sections 6, 7 and 8 are left in the OFF position. The new front panel switch now selects the baud rate for the radio port as well as configuring the modem for 300 or 1200 baud operation. If an external modem is connected to the modem disconnect and is to be selected, the front panel switch is simply placed in the center-off position, preventing any interference with operation of the outboard device.

Very convenient!

The last problem is that of lock detect delay (DCD filtering). The 470k resistor and 0.15 uF capacitor connected to the XR2211 demodulator at pin 3 are chosen for 1200 baud operation. At 300 baud, the response time is a bit fast. Alternatively, setting up the DCD lock for 300 baud operation causes things to be unnecessarily slow at 1200 baud.

The solution I used was to incorporate a 2N3904, transistor switch to connect a 0.47 uF capacitor in parallel with the 0.15 uF at U20 pin 5. The 2N3904 base is connected to the APA circuitry at the front panel switch such that it is biased on (+5 volts) in the 300 baud position and biased off (-5 volts) in the other two positions (off and 1200 baud). A 10k resistor is inserted in series between the 2N3904 base and the baud select switch (red wire). See below.

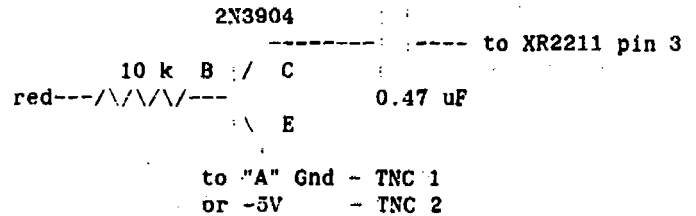

I have used my modified TNC 2 with modified APA modifications (whew!) for several months now and, while I can't guarantee that you will work all the signals you can't hear, it has proven to be a very convenient system for HF operation at WA7GXD.

Contact Amateur Packet Alaska, AX.25 Communications Trail, Esther, AK for current price and delivery on their HF modification for the TNC 2. And of course, TAPR has an HF tuning indicator kit available for a paltry \$25. The combination is dynamite...

See you on 20 meters!

- PRM -

TAPR MOVES TO COMPUSERVE

Pete Eaton, WB9FLW

Effective 1 November 1986 TAPR will move its telecommunications from DRNET to Compuserve's HamNet Special Interest Group.

With this move TAPR hopes to make it's activities and projects more well know to others around the country. At the same time it should make communications between all Packeteers more open.

- PRM -

President - continued from page 9.

NNC UPDATE

The NNC modem board has been made operational. During this month (October), the NNC Alpha sites should be shipped their modem boards! This should serve as another catalyst to get the networking software development effort continuing forward.

Stay tuned!

- PRM -

TAPR DIRECTOR NOMINATIONS

It is that time of year again.

No, I am not referring to congressional and other state and local political contests. I am referring to your TAPR Board of Directors.

As you probably know (but some of you newer members may not), TAPR is governed by a fifteen-member (15-count 'em! That's more than General Motors!) Board of Directors. Each Director serves a term of three (3) years, and, due to staggered terms, one-third of the Board, or five (5) Directors, are elected every year.

The current Directors' terms expire as follows:

Mike Brock, WB6HHV		Feb 1988
Tom Clark, W3IWI	*	Feb 1987
Pete Eaton, WB9FLW	*	Feb 1987
Andy Freeborn, NOCCZ		Feb 1988
Steve Goode, K9NG		Feb 1989
Eric Gustafson, N7CL		Feb 1989
Skip Hansen, WB6YMH		Feb 1988
Lyle Johnson, WA7GXD		Feb 1989
Scott Loftesness, W3VS		Feb 1989
Dan Morrison, KV7B		Feb 1988
Margaret Morrison, KV7D	*	Feb 1987
Harold Price, NK6K	*	Feb 1987
Bill Reed, WDOETZ		Feb 1988
Gwyn Reedy, W1BEL		Feb 1989
Pat Snyder, WA0TTW	*	Feb 1987

Nominations are now open for the seats expiring February, 1987 (marked with an asterisk - *).

Any member of TAPR may nominate any member for the Board.

To place a name in nomination, just send a letter to the TAPR office with the name of the person you wish to nominate (including yourself, if you like). It would be helpful if you would also provide us with your nominee's telephone number and any qualifications you think your nominee has for the office.

We will then get in touch with him (or her) and obtain the person's direct consent to run. At that time we will ask for a statement from the nominee for publication in PSR. (We won't print your picture, so don't let that stop you!)

"What is required of a Director?" you ask.

A Director is expected to attend the Board of Director's meeting and TAPR Annual Meeting in February of every year in which he (or she) holds office. The meetings are held in Tucson, and TAPR does not reimburse expenses for this trip. This means, depending on where you live, a commitment of a few hundred dollars per year.

The Board of Directors reviews the previous year, establishes goals, elects the Officers, and generally guides the organization.

The schedule for this term's election process is as follows:

Event	Time
Request for Nominations	October 1986
Deadline for Nominations	December 15th, 1986
List of candidates and ballot	January 1987

So, submit the name of someone you think will do a good job and get it in to the TAPR office today!

NOMINATION FOR TAPR BOARD OF DIRECTORS

I, _____, as a member of Tucson Amateur Packet Radio, would like to place the name of TAPR member _____ under consideration as a candidate for election to the TAPR Board of Directors.

Signed _____ Date _____

TAPR ANNUAL MEETING

Tucson Amateur Packet Radio will be holding its annual meeting during the weekend on February 21 and 22, 1987.

Your Board of Directors plans to meet all day on Friday, the 20th.

Friday night activities will include the traditional Pizza gathering, followed by racing at the Malibu Grand Prix.

Saturday, the Theatre Royale at the Granada Royale Airport Inn is reserved from 9 AM through 5 PM. The day's activities will include presentations from packeteers from various areas on numerous subjects. As in previous years, a catered lunch will be served.

Saturday night, we will gather at the Triple-C Chuckwagon Ranch for an old-fashioned western meal and entertainment.

Sunday morning the Theatre Royale is again reserved from 9 AM until 1 PM. This is to allow more and better presentations during the meeting.

The early afternoon adjournment should provide ample time for folks to drive home or catch a plane from Tucson International Airport.

More details will be published as the big weekend approaches. If you want to speak, please write to the TAPR office and let us know so we can begin planning early.

See you in February!

NOTE: Since the Board will meet on Friday, all voting must be done by mail. No ballots will be accepted at the annual meeting, so those of you accustomed to procrastinating until then will be find yourselves disenfranchised! Please vote in a timely manner, using the ballot that will be found in your January PSR.

(The following article was submitted to TAPR by JA1DSI. It was written in February of this year, and shows how one enterprising Amateur made an hf modem system for his AEA PKT-1. The idea is similar to that of the AEA PM-1 and PacComm PTU-200.)

HOW TO GET ON HF WITH THE PKT-1

Minoru Tsuda, JA1DSI

WHY MODEM-1 IS TUNED FOR 2125/2325 Hz

We RTTYers use a monitoring 'scope to observe the cross pattern generated by our filter-type TUs (tuning units, or modems). The standard frequency pair used on HF RTTY is 2125 Hz and 2295 Hz. Since tuning HF packet signals can be a tedious chore, I thought it would be good if I could use my existing RTTY monitor scope. By using my RTTY scope and my RTTY TU, I can then precisely tune my rig for best data recovery from my phase lock loop (PLL) based packet demodulator.

In addition, if you have an FSK mode on your HF transmitter, you may use it for sending HF packet signals. It will work best if it can be adjusted to provide a 200 Hz split rather than the more common 170 Hz shift used on RTTY. And, if your rig has an FSK mode, it will probably also use the tone pair of 2125 and 2295 Hz.

Hence, I chose the frequency pair of 2125 Hz and 2325 Hz for 200 Hz shift HF packet work.

AUDIO LEVEL SETTINGS

As you know, the TNC will not send frames if the data carrier detect (DCD) line is on, whether from signals or from noise. For this reason, a CMOS analog switch is installed between the XR2206 tone keyer (1200/2200 Hz) and the AF-output terminal of modem 2.

Without the switch, 1200/2200 Hz tones will be continuously sent to the TNC, resulting in a "channel busy" condition being present at all times. This will prevent the TNC from ever transmitting!

The switch is driven from the DCD output of modem 1. If no signal is detected by modem 1, the tone keyer output will be switched off and the TNC will not be hindered from sending frames. On the other hand, when the demodulator in modem 1 senses a signal (or the right kind of noise!), the switch will be closed and the TNC will "see" the data carrier, thus preventing it from transmitting.

When your computer, TNC, rig and DSI interface (!) are all connected together, you will see the DCD light go bright often with signals from your HF receiver is the audio drive to the demodulator in the DSI interface is adequate.

If the audio level is too high, the DCD light will almost never go off, preventing you from transmitting. If the audio level is too low, you will never decode any HF packet signals!

In the end, you must experiment to find the best audio settings for your HF rig AF gain and the DSI interface's trimmer VR10.

If your HF rig has a squelch control that is effective in the SSB and/or FSK modes, use it as you would use a squelch on VHF/UHF. This will help speed your traffic along. With no squelch control, the AF and RF gain controls must be set carefully or you will spend a lot of time with your DCD LED glowing and your TNC inhibited from sending! This makes HF packet traffic dull and time-consuming!

YOU CAN GET ON HF PACKET RADIO IN "FSK", "LSB" AND "USB" MODES!

If you only operate on VHF/UHF packet radio, you will probably never think about "mark" and "space" polarities at all!

But, on HF F1 (Baudot/AMTOR and Packet Radio), we can't help thinking of this "polarity" problem. It is really important for us on HF RTTY.

At first, when I started on HF packet radio, I thought I had to make the polarity right. But later, I became aware that this is meaningless. Packet radio uses non-return to zero, inverted (NRZI) encoding; a data value of "0" causes a transition between tones and a "1" results in no change of tone. Thus, there is no "mark" or "space" in HF packet.

The end result is that, unlike RTTY, polarity is unimportant for HF packet operation. We can enjoy HF packet with FSK, LSB or USB modes without thinking about polarity. This is fun, strange and fascinating for RTTYers!

ACTUAL ADJUSTMENT OF THE TWO-STAGE MODEM

MODEM 1 (2125/2325 Hz)

XR-2211: Cut 510k-ohm resistor across pins 7 and 8. Connect a DC voltmeter (5 to 10 volt range) between pin 7 and ground. Inject an AC-coupled 2225 Hz tone (this equals $(2125+2325)/2$) into the input terminal of the XR2211 and carefully set VR-4 (10 k-ohm) to cause a transition (0 to 5 volts, or 5 volts to 0). Don't forget to reconnect the 510k-ohm resistor between pins 7 and 8 when you are done.

XR-2206: Connect an oscilloscope at the output terminal of the XR2206. Set the 25k-ohm trimmer (between pins 15 and 16) for a clean sine-wave signal. Set the 50k-ohm trimmer for a stable, large-amplitude sine wave. Next, connect an audio frequency counter at the output terminal of the XR2206 and adjust VR-5 (10k-ohm) for 2325 Hz with pin 9 open and VR-6 (10k-ohm) for 2125 Hz with pin 9 shorted to ground.

MODEM 2 (1200/2200 Hz)

XR-2211: Set this up the same way as modem 1, except inject a 1700 Hz signal and set adjust VR-3 (10k-ohm) for the transition.

XR-2206: Like modem 1, except adjust VR-1 (20k-ohm) for 2200 Hz and VR-2 (30k-ohm) for 1200 Hz.

LOOP BACK TEST (SELF-CHECK)

Without connecting the DSI interface to the HF rig, you can check the modem. Connect AF-IN to AF-OUT of modem 1 and try to send a beacon. Of course, set the TNC to MONITOR-ON. What a strange and fascinating scene we have! We can see our own beacon! If you see your own beacon in this test, your DSI interface is operational.

As a final check, you may want to connect to yourself. Try it!

I have heard that this test is described in the instruction manual for the TNC 2, but I discovered the technique by chance. One day, I happened to be sending a beacon and monitoring the transmitted tones by use of my TS-940S' "MONITOR" on mode. I was quite surprised to see my own beacon on my computer's CRT.

RECOMMENDED PARAMETERS ON HF PACKET RADIO

I do not know the prevailing and common parameters used in the United States. Under my short experience, I have already learned several things through actual contacts. Note that these settings are for the TNC 1.

- (1) AXD: 6 to 10. Longer AXD will send long idles (not frames) and this is very useful and helpful for others to tune in. With a longer AXD, every HF rig can receive and send frames. But too large a value for AXD will make our traffic slow. Try AXD 15 sometime and see what I mean!
- (2) TXD: 4. This means delay time from PTT on to starting to send idle defined by AXD. Not so critical; 1 to 4 seems to be OK. Too long a TXD is useless.
- (3) PACLEN: 40 to 80. Too small a PACLEN makes traffic move slowly because of the need for many ACKs. And we must remember that one frame includes many bits which will not show on our CRT and have nothing to do with the information we wish to send! On the other hand, too long a frame will increase the chance for a bit error due to HF propagation.

(4) MAXFRAME: 1. On HF, with the normal noise, QSB and QRM, bit errors will often occur. Due to these conditions, there isn't much opportunity to ACK several frames at one time. Thus, it is best to send only a single frame at a time. If we use a large MAXFRAME, our traffic will often be stuck for a long time and the link will go down if RETRY is set to other than 0. So, we have to reconnect and fight the QRM, QRN and QSB.

(5) RETRY: 0 (infinite!). There are two schools of thought on this parameter. One is to set RETRY smaller than that on VHF/UHF. In this way, the link often goes down. Worse, the other station may continue to send data indefinitely, not realizing that that our station has RETRYed out and disconnected. This can be demonstrated by setting up our HF station with MONITOR ON, and MCON ON.

Therefore, I would like to recommend that HF stations use RETRY = 0! If both stations in a QSO use this value, we do not need to be afraid of sudden link failures. Besides, we can practice our tuning technique if there are plenty of retries. When you want to disconnect the link, you can always enter CMD: mode and set RETRY to 1, then issue a disconnect command.

(6) MCON: ON (if needed). Generally speaking, we can get clear and beautiful copy with MCON in the OFF state. But, in case you want to see how traffic is on the channel, you can watch things by setting the MONITOR mode ON on your HF rig. This way, you can see how often you retry to get your data through. If things get stuck, you can then disconnect.

- PRM -

BIG DCD-1 INDICATOR

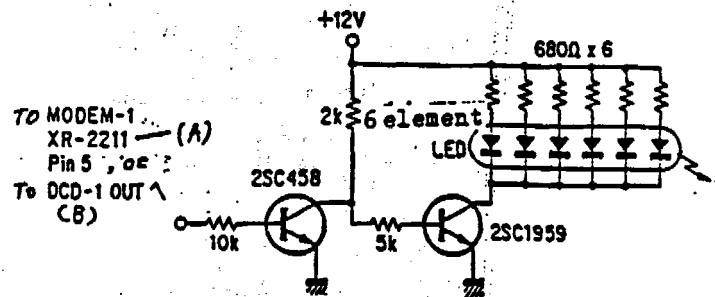

ZERO-IN : LED ON
 OFF QRG : LED OFF
 With noise input, LED goes on and off frequently. This is normal state. Adjustment of AF output level of HF TRX is very important:
 too high : LED is on all the way. TNC will not go to send.
 too low : LED is never on. TNC will not decode anything (you can't receive).

VR-11 is also very important to let this interface work well. It is the best that DCE-LED(PKT-1) and DCD-1(this interface) are on & off in parallel (namely, simultaneously On and Off).

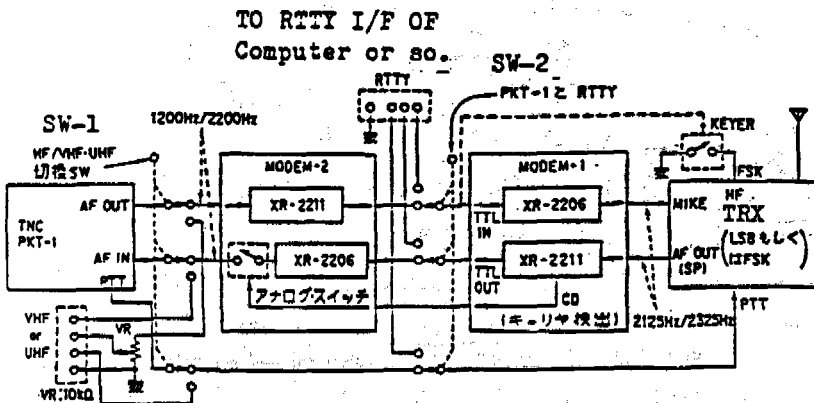

SCHEMATIC DIAGRAM (CONCEPT)

ADA SYSTEM (AUDIO-DIGITAL-AUDIO)

More schematics on page 16.

**AX. 25 WORKS!
SO LET'S CHANGE IT**

Lyle Johnson, WA7GXD

At least one manufacturer of Amateur packet gear has requested a special PID (Protocol Identifier) to allow his TNCs to interrogate a remote unit to see if it can handle special enhancements that manufacturer desires to incorporate in his products.

This was brought to the attention of the ARRL Ad Hoc Committee on Digital Communications at its June Meeting in Newington.

The Committee discussed the proposal and decided that the PID byte was the wrong place to perform this sort of interrogation. Instead, the use of an XID (eXchange IDentifications) frame is indicated. Such a frame exists in many link-layer virtual circuit protocols, including the V-2 protocol being experimented with in Canada.

I have heard of a number of suggestions (complaints?) regarding AX25 Level Two, ranging from perceived errors in the protocol, through enhancements to bug fixes in specific implementations.

What I would like you to do is think about the protocol and any observations you may have on its operation. If you have any suggestions that you think would improve its performance, enhance its reliability or link-level features, please note them and send them to the TAPR Office. If you are proposing a change, please include examples or other arguments supporting your opinion.

These will be compiled and sent on to the ARRL Committee. The next meeting will probably be held before the end of the year, so please act today!

- PRM -

FROM: "Mobile Ham" Magazine
(March, 1986, Tokyo)
How to get on HF with PKT-1
by Minoru Tsua (JA1DSI)

SW-1 and SW-2 are not shown in this figure. Add those if you need.

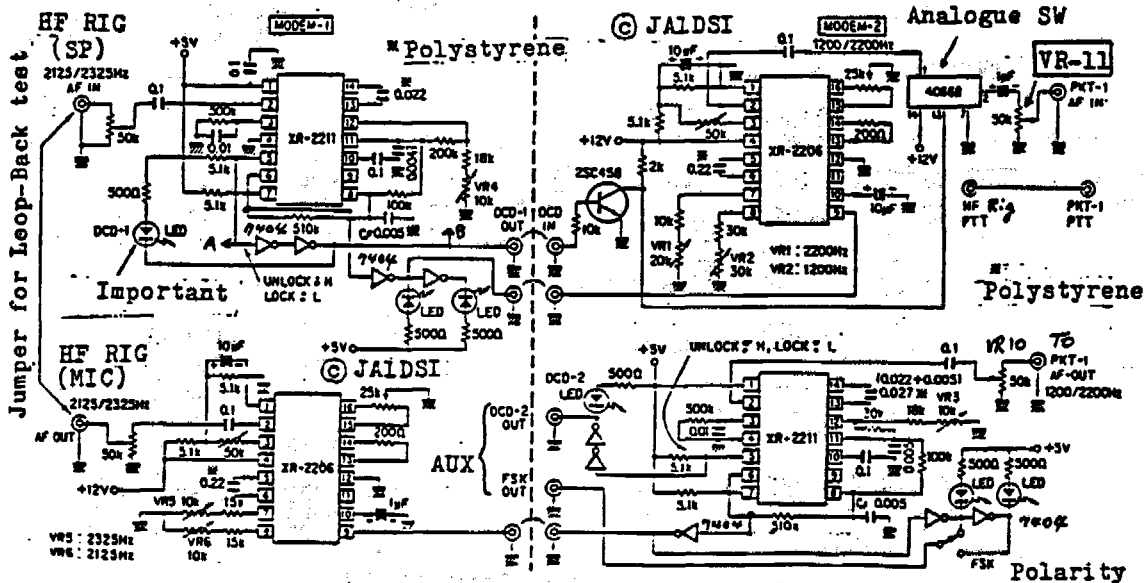

TAPR MEMBERSHIP APPLICATION

Tucson Amateur Packet Radio Corporation
P.O. Box 22888, Tucson, AZ 85734

Name: _____

License Class: _____

Address: _____

City & State: _____ ZIP: _____

Home Phone: _____ Work Phone: _____

If you wish to have any of the above information not be published in a membership list, indicate the items you wish suppressed: _____

I hereby apply for (select one) standard/associate membership in Tucson Amateur Packet Radio Corp. I enclose \$15.00 (standard) / \$5.00 (associate) for one year's membership dues. I understand that \$10.00 of my standard dues are for subscription to the PACKET RADIO MAGAZINE (PRM). Associate members do not receive any publication. The entire amount of the associate membership dues and \$5.00 of the standard dues go to support TAPR's research and development activities in packet radio. My signature indicates that I desire to become a TAPR member, and subscribe to PRM (standard members only).

Signature: _____ Date: _____

The Tucson Amateur Packet Radio Corporation is a nonprofit scientific research and development corporation. The corporation is licensed in the state of Arizona for the purpose of designing and developing new systems for packet radio communication in the Amateur Radio Service, and for freely disseminating information acquired during and obtained from such research.